



BE003100B

Accessories / Accessori / Accessoires / Zubehör / Accesorios

Made in Italy



All the described operations of this instructions page must be done by specialized personnel only, shutting of the electrical power and respecting all national installation regulations and guidelines.

*Tutte le operazioni descritte in questo foglio di istruzioni devono essere eseguite da personale specializzato, escludendo tensione dall'impianto e rispettando le norme nazionali di installazione.*

Toutes les opérations décrites sur cette page d'instructions doivent être effectuées par un technicien spécialisé. La tension d'alimentation doit être coupée et la réglementation applicable dans le pays doit être respectée.

*Alle vorzunehmenden Installationen sind nur durch Fachpersonal durchzuführen. Schalten Sie die Anlage vor der Montage aus. Beachten Sie bitte die nationalen Installationsvorschriften.*

Todas las operaciones descritas en esta hoja de instrucciones deben ser ejecutadas por personal especializado, desactivando la alimentación eléctrica y respetando las normas nacionales de instalación.



The distributor is obliged to provide its customers with guidance on the correct use of all components supplied.

*Il distributore ha l'obbligo di informare l'utente sulle modalità di utilizzo di tutti i componenti forniti.*

Le distributeur est tenu d'informer l'utilisateur sur les modalités d'utilisation de tous les composants fournis.

*Der Händler ist verpflichtet, den Benutzer über die Verwendungsart aller gelieferten Komponenten zu informieren.*

El distribuidor tiene la obligación de informar al usuario de las modalidades de uso de todos los componentes suministrados.



Materials, design, our development program and packages may be subject to changes without notice.

*Materiali, disegni, programma di fabbricazione e confezioni possono subire modifiche o variazioni senza obbligo di preavviso.*

Les matériaux, les dessins, le programme de fabrication et les emballages peuvent subir des modifications ou varier sans obligation de préavis.

*Materialien, Zeichnungen, Herstellungsprogramm und Verpackung können Veränderungen unterliegen, ohne dass dies vorher mitgeteilt werden muss.*

Materiales, dibujos, programa de fabricación y envases pueden sufrir modificaciones o variaciones sin aviso previo.



We decline responsibility for any misprint.

*Si declina ogni responsabilità per eventuali errori di stampa.*

Nous déclinons toute responsabilité en cas d'erreurs d'impression.

*Jegliche Haftung für eventuelle Druckfehler ist ausgeschlossen.*

Se declina toda responsabilidad por errores de impresión.

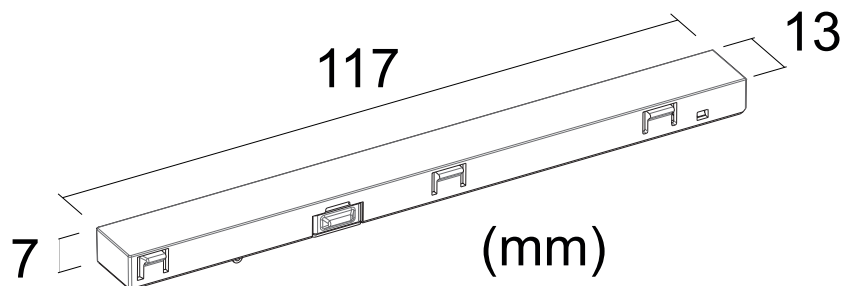

# 1 BE0030012/25

## BE003100B

End use

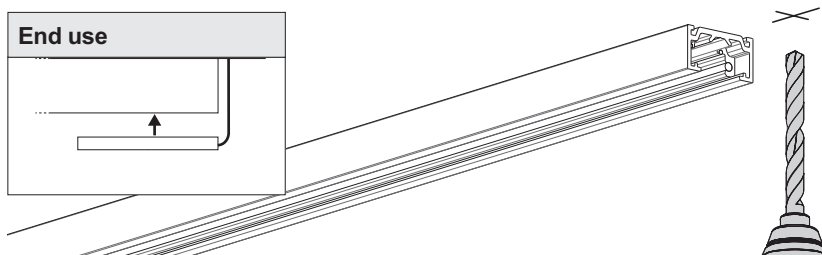

# 2

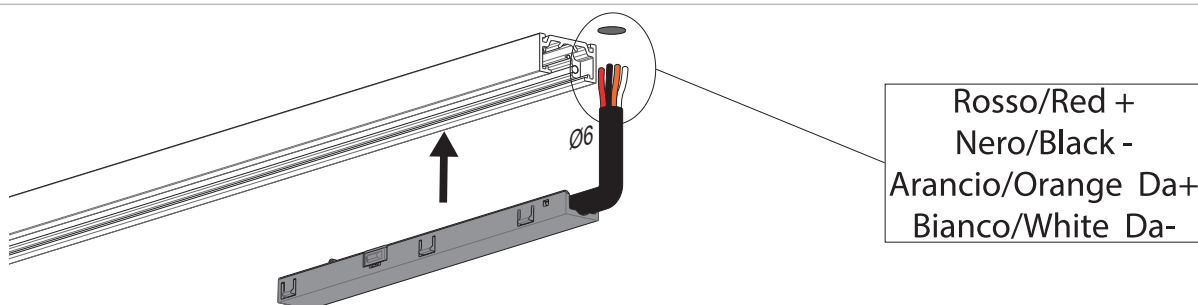

# 3

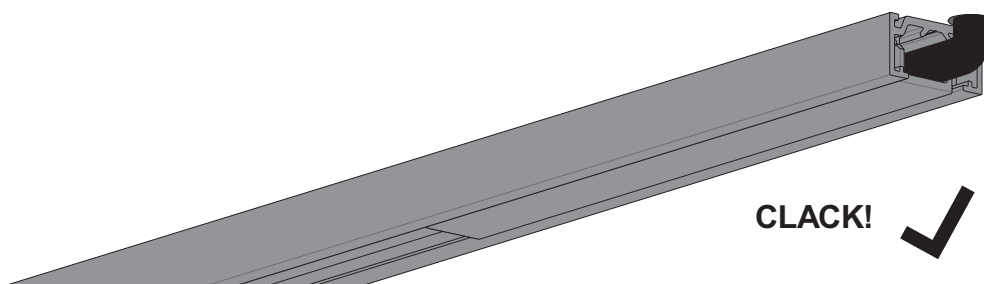

# 1 BE0030004/5

Rosso/Red +  
Nero/Black -  
Arancio/Orange Da+  
Bianco/White Da-

## BE003100B

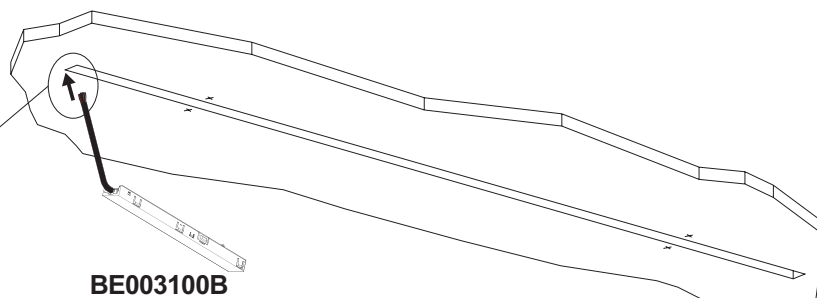

# 2

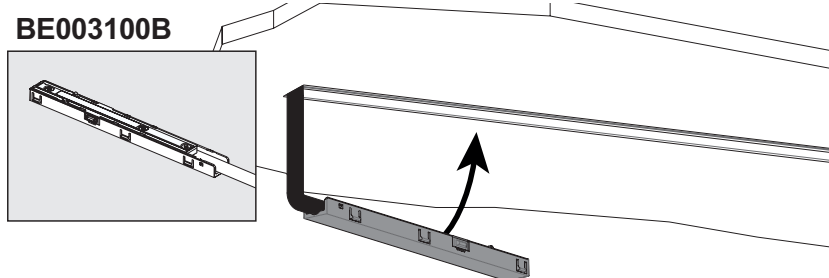

# 3

